



PRS Blast & Recovery Systems

Reduce Operating Costs & Improve Finishes

Tunable media reclaimer

assures high-quality results by recycling only the correct-size media. Ultrawear lining on reclaimer interior provides excellent durability.

SuperBlast® pressure system, with dependable Sure-Flo® grit valve, simplifies maintenance and yields high production rates.

Media recovery hopper can be moved around work area for easy media retrieval. Optional long troughs allow media to be swept into system without shoveling.

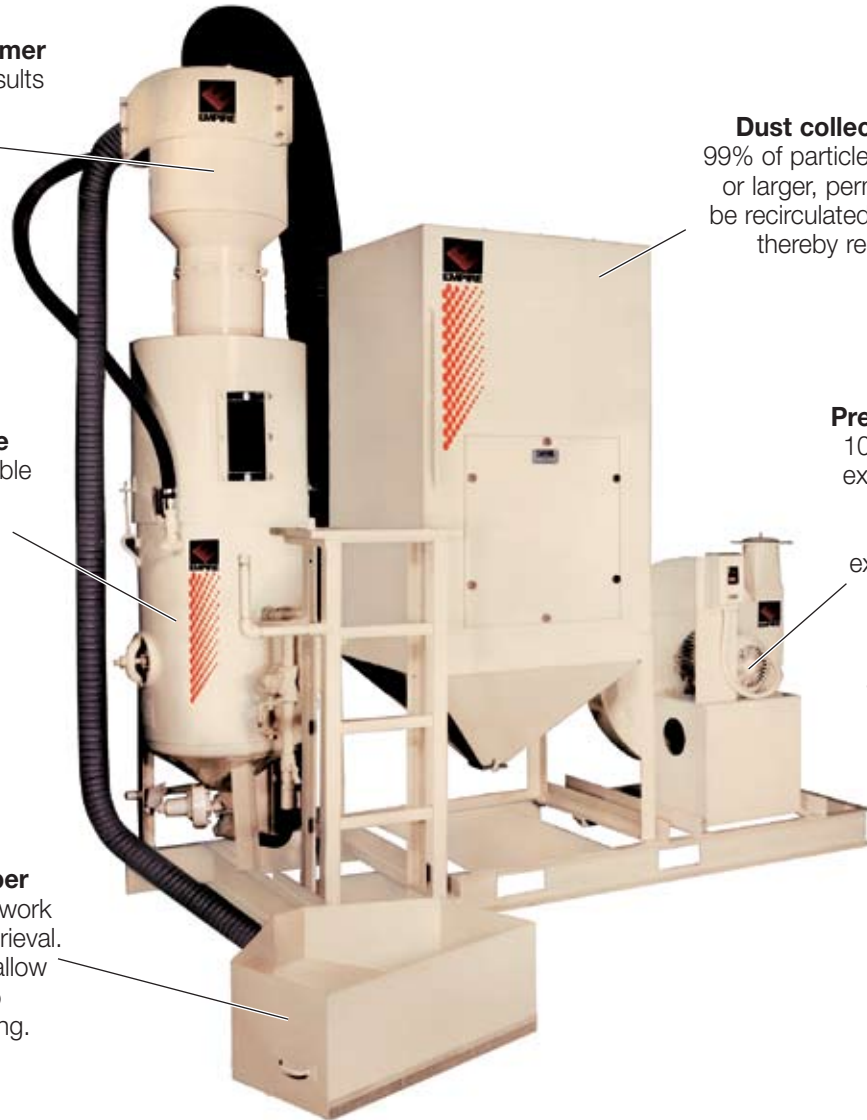

Dust collector, which captures 99% of particles one micron in size or larger, permits conveying air to be recirculated into the workplace, thereby reducing HVAC costs.

Pressure blower, with 10-horsepower motor, extends effective work area and recovers media at rates exceeding 70 pounds per minute. System handles media sizes up to A-12 aluminum oxide and G-25 steel grit.

Using “economical” blast media, such as slag, for industrial blasting can be very costly indeed. Because these low-cost abrasives break down so quickly, reusing them is impractical. As a result, you’re constantly paying for replacement media, disposal of spent media, and manhours to move this material around—all of which can put a big drain on your profits.

With Empire’s pneumatic Blast & Recovery System (PRS), you can tap the cost-saving advantages of more durable media for only a modest investment. Empire’s PRS lets you move up to recyclable media, such as aluminum oxide, chilled iron and steel grit, which can be used effectively over and over—from 6 to 200 times. The result is usually a very attractive return on investment in media savings alone.

Reusable media are also faster acting and less dusty, meaning you get the additional advantages of increased productivity and a cleaner working environment. With the PRS, you can move blasting operations into enclosures to comply with increasingly stringent environmental regulations. And, because the PRS recycles good media while removing dust and fines, blasting results are more consistent.

Simple blast controls and convenient media-loading procedures make Empire’s PRS very easy to operate. A built-in access ladder and viewing window in the system’s storage hopper are just two examples of the PRS’s many friendly features. And, with heavy-duty duct, an Ultrawear-lined reclaimer, and a silicone carbide nozzle, you know the system is designed to last.



OPTIONS

- Fan silencer
- Automatic bag shaker
- Vibrating reclaimers screen
- Operator safety equipment
- Multiple operators
- Electric remote controls
- Various electricals
- Magnetic particle separator
- Room ventilation dust collectors
- 8', 10', and 12' sweep-in recovery troughs
- SuperBlast® portable options and upgrades
- Large, free-standing, media-storage hoppers

Optional media-recovery trough is installed flush with the floor to enable sweep-in loading of recyclable media.

Self-metering, anti-clogging design permits large amounts of media to be loaded into the system without operator attention.

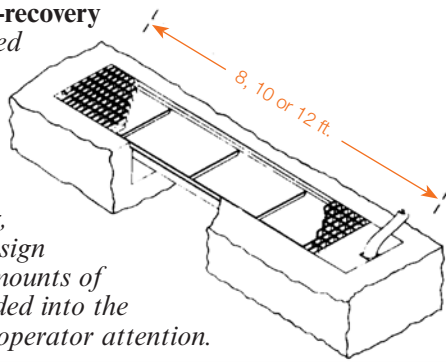

SURE-FLO® GRIT VALVE

Patented Automatic Sure-Flo® valve is easily adjustable and assures precise media regulation as well as uninterrupted flow.

The Sure-Flo valve has excellent wear characteristics and, once worn, can be repaired more quickly and easily than any other grit valve on the market.

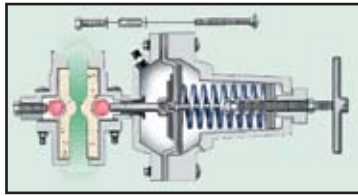

PLAN VIEW

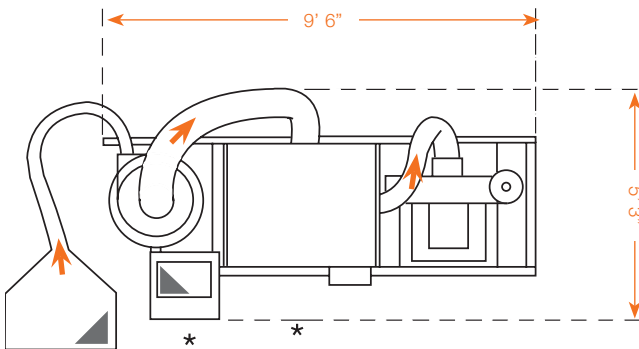

NOTES:

- Access areas are noted by asterisks (*) in plan view.
- Arrows within drawing indicate direction of flow.
- Total system height is a nominal 12 feet.

Silica sand is not to be used in any Empire blast equipment.

BEST WARRANTY IN THE INDUSTRY
Three years limited on parts and labor.

Information subject to change without notice.

SYSTEM SPECIFICATIONS

Model No.	Part No.	Blast System
PRS-6	245006	Mounts to 650 pot
PRS-6CDC	245007	Mounts to 650 pot, includes CDC collector
PRS-6S	247106	Includes SuperBlast 650 pot
PRS-6SCDC	247107	Includes SuperBlast 650 pot & CDC collector
PRS-10	245010	Mounts to 1050 pot
PRS-10CDC	245011	Mounts to 1050 pot, includes CDC collector
PRS-10S	247110	Includes 1050 SuperBlast pot
PRS-10SCDC	247111	Includes 1050 SuperBlast pot & CDC collector

Skid chassis is standard.

All models available with optional dolly chassis for mobility.

Media Recovery Hopper

- 11-gauge, welded-steel construction
- Anti-clogging refuse screen
- 30" wide x 30" deep x 12" high

Media Conveying Duct

- 4" ID x 25" long—Heavy-duty construction

Media Reclaimer

- Rugged, 12-gauge, welded-steel construction
- Ultrawear lining with externally replaceable wearplate
- Tunable to various media sizes
- 800 CFM ventilation

Media Storage Hopper

- 11-gauge, welded-steel construction
- Viewing window
- Capacity: 6.5 ft³ with PRS-6 models; 10.5 ft³ with PRS-10 models
- Nominal diameter: 24" on PRS-6 models; 30" on PRS-10 models

Pressure Vessel ("S" models)

- SuperBlast 650 or 1050, ASME construction
- 780 remote controls with automatic Sure-Flo® grit valve*
- 1-1/4" piping
- Capacity: 6.5 ft³ with PRS-6 models; 10.5 ft³ with PRS-10 models
- Moisture separator/filter and choke feature

Blast Apparatus ("S" models)

- 5/16", silicone-carbide, venturi nozzle
- 1"-ID x 50'-long, heavy-duty blast hose with couplings
- Saf-Stop II™ pneumatic blast-control handle† (OSHA)
- 55' dual-line pneumatic control hose

Dust Collector/DCM-200 HV (High Vacuum)

- 14-gauge, welded-steel, reinforced construction
- 200 ft² filtration with 30 cotton-sateen bags
- Large access door; raised clean-out door
- Push-button, pneumatic cleaning

Pressure Blower

- 10 hp, 3450 RPM, 800 CFM (at 42" static pressure H₂O)
- 440-480 V, 60 Hz, fused disconnect

Chassis

- Heavy-channel iron, welded and reinforced
- Access ladder with hand holds
- Cut-outs for forklift transport
- Heavy-duty rubber casters on "D" and "SD" models

* Patent No. 4,518,145

† Patent No. 3,834,082

OTHER EMPIRE PRODUCTS

- Blast Rooms
- Portable Blasters
- Automated Blast Systems
- Blast Cabinets—economy to custom